

Concept with Wall Mount Gas Extract System

Inert Gas Extract System



The MPVX300, 500 and 700 wall mounted gas extract models are high performance units comprising an internal steel grille, Damper Mounting frame, Motorised damper, adjustable wall sleeve, plate axial fan and air operated external dynamic weather louvre, designed to provide powerful extract for gas extinguishing systems.

Aesthetic design – This stylishly designed and easy to install unit enables simple but effective extract of gaseous fire protection systems. Designed to be mounted to any external wall and able to extract up to 4000m³ per hour with special fan. This system provides the best option for inert gas system extract. The PVX300, 500 and 700 are also simple to control as the damper and fan operate when power is switched to the unit. This can be simply controlled via the fire alarm panel by switching the mains supply by a relay via a gas extract key switch.

- High Performance Axial impeller
- Two Standard Sizes
- Motorised Damper for Air Sealing
- Air volume rates of up to 1.55m³/sec
- Highly efficient lightweight induction motor with Class F Insulation
- Motor fitted with thermal overload protection
- 240 and 24 volt motorised Damper
- Can combine pressure venting with extract
- 60% Free Vent Areas provided
- Tested to ISO 5801:1997 (airside performance)
- Tested BS 848 Pt 20:1985 (sound performance)
- Supplied with integral IP55 terminal box
- Motor have sealed for life bearings

NOTE

The fitting of Gas Extract Systems is only a recommendation although where it is not used an alternative means of venting should be identified to comply with BS15004-1:2008.

As a standard all our Extract Systems are designed to 4 exchanges of air per hour.

Concept with Wall Mount Gas Extract System



CONCEPT
FIRE SUPPRESSION LTD

Inert Gas Extract System

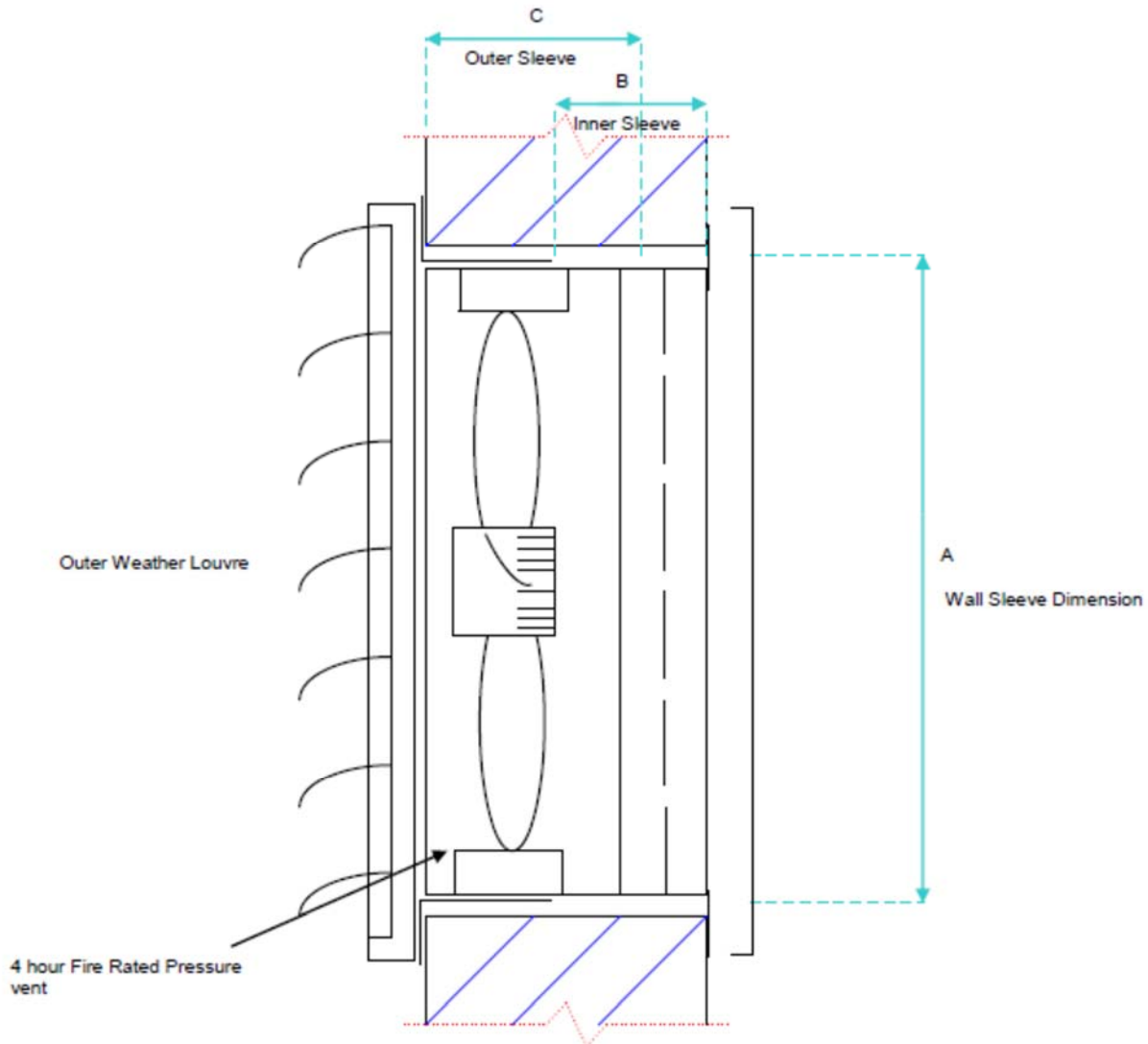

Product Code	Width (mm)	B (mm)	C (mm)	Height (mm)	Weight (Kg)	Fan Diameter (mm)	Speed (RPM)	Power (Amps)	M3/Sec	dBA@ 3m	Free Vent Area (mm ²)	Wall Opening (mm)
MPVX300	350	150	150	370	43	250	2725	0.48	0.2	65	0.049	350x370
MPVX500	550	150	150	635	54	450	1380	1.76	1.1	78	0.15	545x625
MPVX700	750	150	150	770	95	630	1450	9.8	2.2	82	0.24	750x770

Concept Fire Suppression Ltd
Unit 4, The Stables, Newby Hall,
Ripon, North Yorkshire,
UK, HG4 5AE.
Tel: +44 (0)1423 900883
Fax: +44 (0)1423 301898

Concept Fire Suppression Ltd
Hudson House, 8 Albany Street,
Edinburgh, UK, EH1 3QB.
Tel: +44 (0)131 516 7590
Fax: +44 (0)131 473 2309

Concept Fire Suppression Ltd
Albany House, 14 Shute End
Wokingham, Berkshire,
UK, RG40 1BJ.
Tel: +44 (0)203 411 3212
Fax: +44 (0)845 250 8101

Web: www.conceptfire-uk.com
E-mail: info@conceptfire-uk.com